

item



Systematic innovation.

New Products 2016/ I



Experience innovation – new item products for 2016/ I.

4 MB Building Kit System

New capacities! The new **Installation Profile 8 160x80 K76** offers plenty of space for supply lines and cables. It features a generously sized cable conduit, two integrated compressed air conduits and can be fitted with numerous pneumatic accessories.

New safety! The item **Corner Deflector Guard 8 St 160x160x80** protects transport trolleys like a bumper. It prevents damage to supporting profiles that could collide with walls or racks when turning. The robust steel protection considerably reduces wear.

New lightness! The item **Tool Balancers** make work with heavy tools safer. The Tool Balancers make sure tools are in easy reach but automatically remove them from the immediate working area when not in use.

22 Work Bench System

New organisation! Our **Dividers 600** support ergonomic and simple container restocking at work benches. The narrow ribs ensure that semi-open fronted boxes are properly organised and lined up in the correct picking positions. If picking systems are changed, the Dividers can be rapidly adjusted.

New orientation! The new **Back Stop Insert ESD** makes sure that crates and goods move in only one direction on interlinked work benches fitted with the modular **Castor Rail 8 40x40**. When used on mobile material supply equipment, it acts as a transport securing device.

New choice! **Cantilever Foot Set 8**, **Table-Top Support Set 8** and **Profile 8 160x60 6N E** can be used to build fully customized work benches. They are the basis for stable work benches.



33 Lean Production Building Kit System

New inclination! The new **Ball Joint Butt Fastener D30** connects the end faces of two Profiles D30 at any angle. As a result, it can turn the outer Tubes of a transport trolley into angled grips for pulling or pushing the equipment around. Angled outer edges also make it easier to pass through strip curtains.

New size! Lots of things run more smoothly with the new **Roller Conveyor St 60x24 D15**. Its combination of low height and wide rollers make it ideal for most transported goods. The robust Roller Conveyor is easy to install. What's more, it is also easy to fit with **Guide Rail e 4**, which along with **Fastening Profile D30-60** gives the Roller Conveyor additional rigidity.

New restraint! Controlling speed on Roller Conveyor 6 40x40 is the speciality of the new **Braking Castor D30-23**. It slows down crates and goods according to their travel speed. Depending on their weight, they can be very accurately slowed down to prevent major impacts at the Limit Stop.

New material! Profile Tube System D30 now comes in carbon! The extremely torsion-resistant **Tube D30x1.5 CFRP** combines low weight with maximum strength! It is ideal for weight-optimised applications in production and intralogistics.



Factory equipment engineering – with the MB Building Kit System.

Profile 8 80x40 3N90 light
Profile 8 120x40 3N light
Cap 8 80x16 Zn
Cap 6 D11
Spanner 65A/F / 17A/F flat
Security Bit Set 2A/F – 6A/F

Installation Profile 8 160x80 K76
Caps 8 St
Face Plates M45 with Labelling Panel, Horizontal
Pneumatic components
Tool Balancers
Corner Deflector Guard 8 St 160x160x80

Consider the matter closed.

For stable frames

Unbroken surfaces

Easy to clean



Profile 8 80x40 3N90 light
Profile 8 120x40 3N light

For strong and clean frames! Profile 8 80x40 3N90 light features closed grooves on two outer edges and is ideal for building solid framework for cabins and frames.

The wide Profile 8 120x40 3N light is torsion resistant and gives frames that are exposed to transverse loads additional stability. Closed grooves on the outer face seal out dust and deposits.

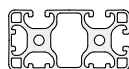

Profile 8 80x40 3N90 light



Al, anodized

A [cm ²]	m [kg/m]	I _x [cm ⁴]	I _y [cm ⁴]	I _z [cm ⁴]	W _x [cm ³]	W _y [cm ³]
11.75	3.17	17.70	73.25	19.61	8.65	18.09
natural, cut-off max. 6000 mm						0.0.674.52
natural, 1 pce., length 6000 mm						0.0.674.51

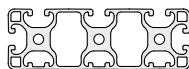

Profile 8 120x40 3N light



Al, anodized

A [cm ²]	m [kg/m]	I _x [cm ⁴]	I _y [cm ⁴]	I _z [cm ⁴]	W _x [cm ³]	W _y [cm ³]
16.57	4.48	25.80	226.04	31.29	12.58	37.67
natural, cut-off max. 6000 mm						0.0.675.52
natural, 1 pce., length 6000 mm						0.0.675.51

Crash proof.

Impact-proof

Colour coordinated



Cap 8 80x16 Zn

Better protection for flat Profile 8 80x16! This robust metal Cap guards against even hard impacts and seals the end face of the profile.

Thanks to its special shape, it is ideal for use with Profile 8 80x16 when designing guides or guide elements. It is also used as a flat cap and as simple collision protection, when it is often subjected to high impacts. Cap 8 80x16 Zn is therefore fixed to the screw channels of the profile using the enclosed screws to create a strong friction-based connection, which ensures it can resist impacts and vibration over long-term use.

For low-stress applications, Cap 8 80x16 is available in grey and black (0.0.627.25 and 0.0.265.98). The plastic version is tapped into place using a hammer.

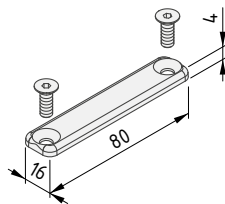

Cap 8 80x16 Zn

Cap, die-cast zinc, white aluminium
2 Countersunk Screws DIN 7991-M5x14, St, bright zinc-plated
m = 24.0 g

1 set

0.0.674.71



You're covered.

Clean

Safe

Uniform



Cap 6 D11

Perfection down to the smallest detail! When screwing together two Line 6 profiles, users have to drill through one profile to reach the core bore of the other profile. Cap 6 D11 seals off the hole. This ensures that cut edges are safely covered over and keeps dust out of the drilled hole.

What's more, the colour-coordinated Cap preserves the uniform look of Line 6 profiles with closed grooves.

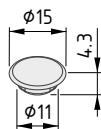
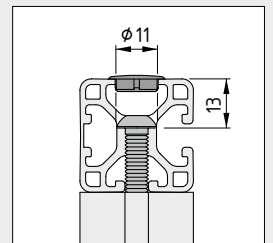

Cap 6 D11

PA
m = 30 g/100

grey similar to RAL 7042, 1 pce.



0.0.672.31

Super spanner.

Flat and versatile

Ideal for Jacking Castor D62



Spanner 65A/F / 17A/F flat

Optimum force transmission even in tight spaces! Spanner 65A/F / 17A/F flat makes it extremely easy to tighten and adjust Jacking Castors D62. It combines all the key widths that are relevant to the Jacking Castors.

Jacking Castors D62 boast optimum mobility, thanks to a stable castor, and a solid footing, thanks to an extendible foot. The latter is operated via an adjustment wheel. When under heavy loads, an additional small 17 A/F wrench is also needed. The item Spanner 65A/F / 17A/F flat is compact enough that it is easy to use close to the floor and long enough that strong leverage can be generated.

The opposite end of Spanner 65A/F / 17A/F flat features a large 65 A/F wrench for fitting Jacking Castor D62 (0.0.674.53) to the profile. As a result, one tool is all you need to do everything.

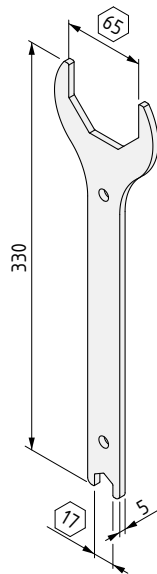

Spanner 65A/F / 17A/F flat

St, bright zinc-plated
m = 416.0 g

1 pce.

0.0.671.12

Restricted access.



For item security bolts

Security Bit Set 2A/F – 6A/F

Access for authorised personnel only! Products fitted with item Security Bolts cannot be opened or fastened using conventional bit sets. The security pin in the centre prevents the insertion of a hex bit. item Security Bolts thus offer effective protection from unauthorised tampering.

Security Bit Set 2A/F – 6A/F has the appropriate depression in all five sizes. item security bolts are used as standard with the following products:

- Safety Switch 8, 24V DC (0.0.658.28)
- Safety Fastening Set Multiblock 8 (0.0.626.63)
- Safety Hanger 8/6 (0.0.627.78)
- Safety Hanger 8/8 (0.0.626.00)

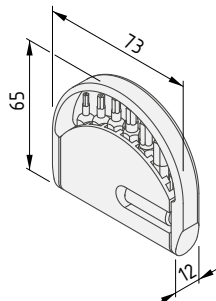

Security Bit Set 2A/F – 6A/F

Security bit TR2; 2.5; 3; 4; 5; 6, chromium-vanadium steel
 Universal Holder, St
 in plastic case, black
 m = 68.0 g

1 set

0.0.661.47

Fully supplied.

Integrated cable conduit

Two compressed air conduits

Suitable as integral and standalone solution



Installation Profile 8 160x80 K76

The turnkey solution for all your supply needs! Installation Profile 8 160x80 K76 is a cable conduit, a dual compressed air conduit, a hub for plugs and switches and a load-bearing profile – all in one solution. Power and network cables can be safely routed through the large cable conduit, which can be divided into different sections. Outlets and switches can be easily clipped into the conduit opening. Two sealed conduits can convey compressed air to precisely where it is needed. Two Line 8 grooves on each side can be used to attach accessories or connect the profile to frames of any type. When built into work benches, the Installation Profile can be used as a robust aluminium cable conduit. It can be installed horizontally and vertically.

Installation Profile 8 160x80 K76 is compatible with Installation Column Profile 8 160x160 K76 (0.0.663.39). All accessories such as mounting boxes K76, switches, plugs and Cover Profile 76 AI (0.0.663.41) for covering over the cable conduit can be used.

Note: Installation Profile 8 160x80 K76 is also available in complete sets for installation in item work benches. You can find detailed information on page 29.



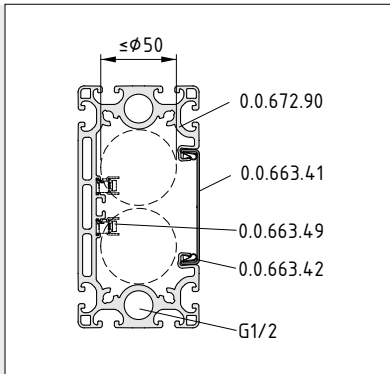

Installation example showing Installation Profile 8 160x80 K76 with Cover Profile 76 Al (0.0.663.41), Locking Clip St (0.0.663.42) and Earth Connection, Installation Column Profile (0.0.663.49).
The maximum available clearance in the conduit is 50 mm in diameter.

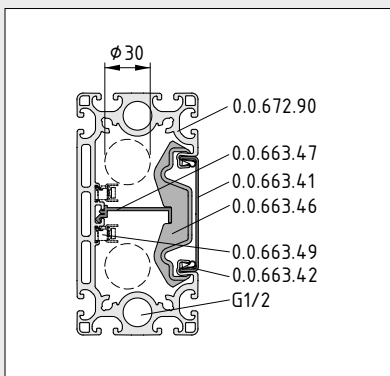

Installation example showing Installation Profile 8 160x80 K76 with the conduit divided using Partition Profile K76 K (0.0.663.47) and Partition Profile Clip K76 K (0.0.663.46).
The maximum available clearance in the conduit is 30 mm in diameter.

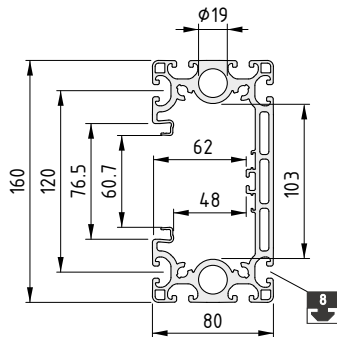

Installation Profile 8 160x80 K76



Al, anodized

A [cm ²]	m [kg/m]	I _x [cm ⁴]	I _y [cm ⁴]	I _z [cm ⁴]	W _x [cm ³]	W _y [cm ³]
28.01	7.56	937.38	191.32	15.76	117.23	41.23
natural, cut-off max. 6000 mm						0.0.672.90
natural, 1 pce., length 6000 mm						0.0.672.89



When combined with Base Plate, Installation Profile 160x80, Installation Profile 8 160x80 K76 can be used in a free-standing application, as an anchor point for a safety barrier or as a vertical strut in a construction. The fastening materials for the Installation Profile are included in the scope of supply. The Base Plate can, for example, be doweled with four additional Floor-Fastening Sets M10x135 (0.0.485.82).

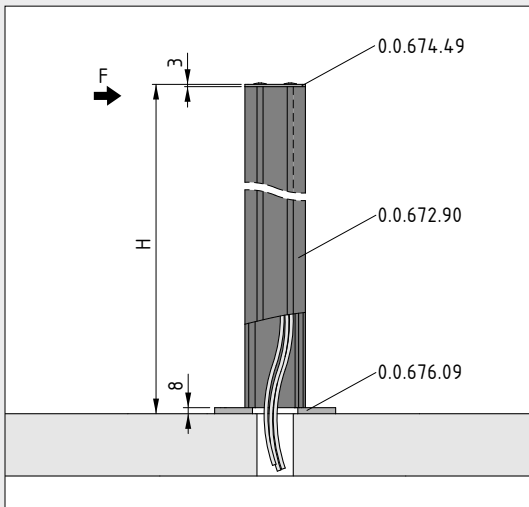

Maximum torsional moment, such as for cracked C20/C25 concrete and Floor-Fastening Set M10x135 (0.0.485.82):
 $F \times H < 600 \text{ Nm}$

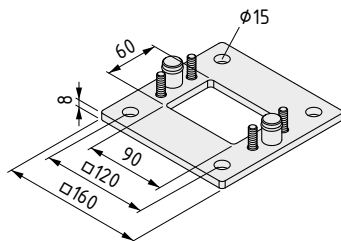

Base Plate, Installation Profile 160x80



Floor flange 160x160, St, white aluminium similar to RAL 9006
 2 Sealing Plugs D19
 Fastening elements
 Notes on Use and Installation
 $m = 1.2 \text{ kg}$

1 set

0.0.676.09

A clear edge.



Clean closure for Installation Profiles

Secure hold for Sealing Plugs



Caps 8 St

The perfect and safe finishing touch! The screw-attached Cap 8 160x80 St seals the end-face of Installation Profile 8 160x80 K76. Cap 8 160x160 St is used with Installation Column Profile 8 160x160 K76 (0.0.663.39).

The Cap, combined with Cover Profile 76 Al (0.0.663.41), keeps dust out of the cable conduit. It is advisable to fit the Cap when using Sealing Plugs D19, as it ensures the Sealing Plugs cannot be forced out of the compressed air conduits. It also covers over cut edges safely.

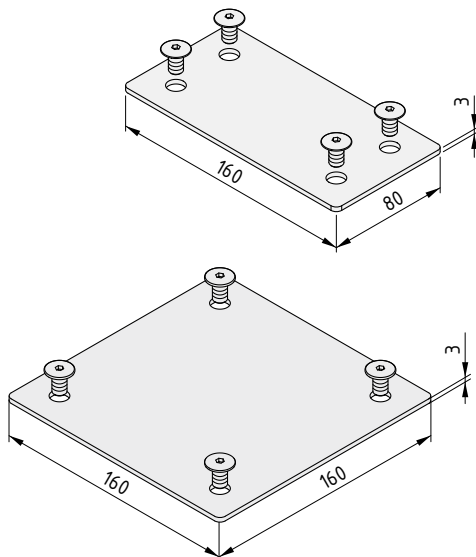

Cap 8 160x80 St



Cap 8 160x80, St, white aluminium similar to RAL 9006
4 dome-head screws M8x14, St, bright zinc-plated
m = 324.0 g

1 set

0.0.674.49

Cap 8 160x160 St



Cap 8 160x160, St, white aluminium similar to RAL 9006
4 dome-head screws M8x14, St, bright zinc-plated
m = 625.0 g

1 set

0.0.674.57

Sideways stability.

For horizontal installation

Secure and clear



Face Plates M45 with Labelling Panel, Horizontal

Keep things clear at the work bench! Face Plates M45 with Labelling Panel, Horizontal encompass one, two or three Mounting Boxes K76 and feature a horizontal labelling panel. This is important if Installation Profile 8 160x80 K76 is being used on work benches as a robust, horizontal aluminium cable conduit. It ensures that the labels can be easily read. The Face Plates are available in white and black grey.

Note: item supplies vertical Face Plates M45 with Labelling Panel for Installation Profiles that have been installed vertically.

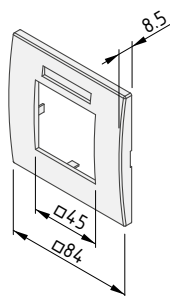

Face Plate M45 1 Gang with Labelling Panel, Horizontal

PC

m = 17.0 g

white, similar to RAL 9010, 1 pce.

0.0.675.75

black grey, similar to RAL 7021, 1 pce.

0.0.675.76

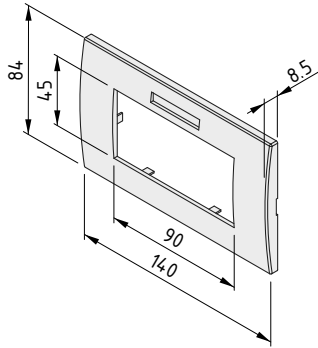

Face Plate M45 2 Gang with Labelling Panel, Horizontal

PC

m = 24.0 g

white, similar to RAL 9010, 1 pce.

0.0.675.77

black grey, similar to RAL 7021, 1 pce.

0.0.675.78

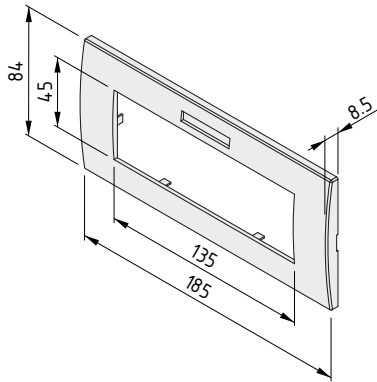

Face Plate M45 3 Gang with Labelling Panel, Horizontal

PC

m = 29.0 g

white, similar to RAL 9010, 1 pce.

0.0.675.79

black grey, similar to RAL 7021, 1 pce.

0.0.675.80

Solutions that are a breeze to use.

For a perfect pneumatic air supply

Simple to use

Outlets wherever required



Pneumatic components

The easy way to use pneumatic applications with Installation Profile 8 160x80 K76! Simply use Pneumatic Connecting Set 8 80x40 G1/2 to connect to a compressed air supply. It can be fitted to any point along the narrow edge of the profile, once a through-hole has been drilled to the integral compressed-air conduit. The drill template is included in the scope of supply. The through-hole is predrilled with a 10.0 mm drill and then widened to 12.7 mm.

Note: Pneumatic Connecting Set 8 160x40 G1/2 is used with Installation Column Profile 8 160x160 K76. Accessories such as Sealing Plugs and the Screw Plug can be used on both the Installation Profile and the Installation Column.

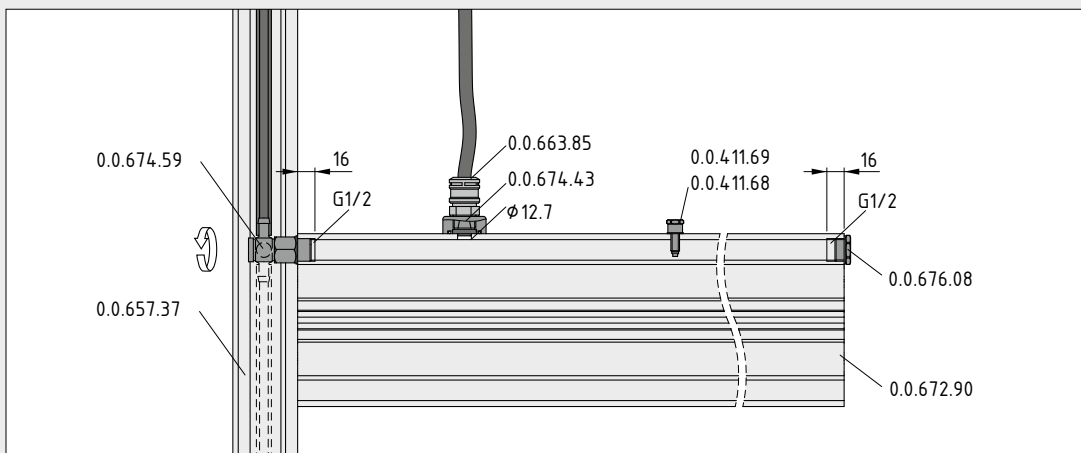



If space for a compressed air connection is limited, such as when using the Installation Profile as part of a work bench, Banjo Connector G1/2 for 9 mm hoses offers a swivelling right-angled connection. When using this device, the compressed air supply can be swivelled 360° steplessly.



Screw Plug with Shoulder G1/2 can be used to reliably close and seal the compressed-air conduit.



Sealing Plug D19 creates an airtight seal in a compressed air conduit on Installation Profile 8 160x80 K76 and Installation Column Profile 8 160x160 K76 (0.0.663.39). It is advisable also to fit the screw-fastened Cap 8 160x80 to the Installation Profile and/or Cap 8 160x160 to the Installation Column Profile so as to prevent the Sealing Plugs being forced out of the conduits. They are not connected to the Caps, which prevents leakage when the Installation Profiles are subjected to transverse loads.

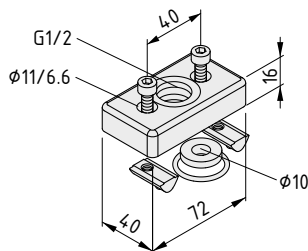

Pneumatic Connecting Set 8 80x40 G1/2



Pneumatic connecting plate 8 80x40 G1/2, Al, white aluminium similar to RAL 9006
 O-ring 25x2.5, NBR, black
 2 Hexagon Socket Head Cap Screws DIN 912-M6x20, St, bright zinc-plated
 2 T-Slot Nuts V 8 St M6, bright zinc-plated
 Drill template
 Notes on Use and Installation
 m = 141.0 g

1 set

0.0.674.43

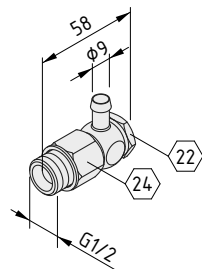

Banjo Connector G1/2 for Hose 9 mm

Banjo Connector G3/8, CuZn, nickel-plated
 Reducing nipple G1/2 G3/8, CuZn, nickel-plated
 Gasket DIN 7603-A 21x26, Al
 m = 147.0 g

1 set

0.0.674.59

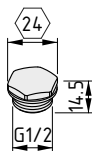

Screw Plug with Shoulder G1/2

Screw Plug with Shoulder G1/2, CuZn, nickel-plated
 Flat gasket DIN 7603-A 21x26, Al
 m = 29.0 g

1 set

0.0.676.08

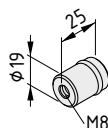

Sealing Plug D19

Sealing Plug D19, Al
 O-ring DIN 3771 15x2.5, NBR, black
 m = 16.0 g

1 set

0.0.674.47



Up, down and back again.

Keep tools close by and at the right height

For weights up to 14 kg

Relieves strain on employees



Tool Balancers

Out of the way, but close to hand! Tool Balancers from item ensure tools are at the right height for employees to reach. When not required, the Tool Balancer automatically removes the tool from the immediate working area. Because the retraction force can be manually set, the Tool Balancer can be adjusted to perfectly match the weight of the tool. This takes a considerable amount of strain off employees who are working with heavy tools. An arrester mechanism is also included as standard.

Hangers are available as appropriate to the weight of tools. The four Tool Balancers can be selected for the following weight ranges: 4 to 6 kg, 6 to 8 kg, 8 to 10 kg and 10 to 14 kg.

Employees can customise any of the Tool Balancers to their reaching height using a screw-adjusted stopper. Useful accessories include Runway Profile 8 40x40 (0.0.623.61), Tool Slide 40x40 (0.0.653.41) and Spring Hook 80 D8 (0.0.619.70).

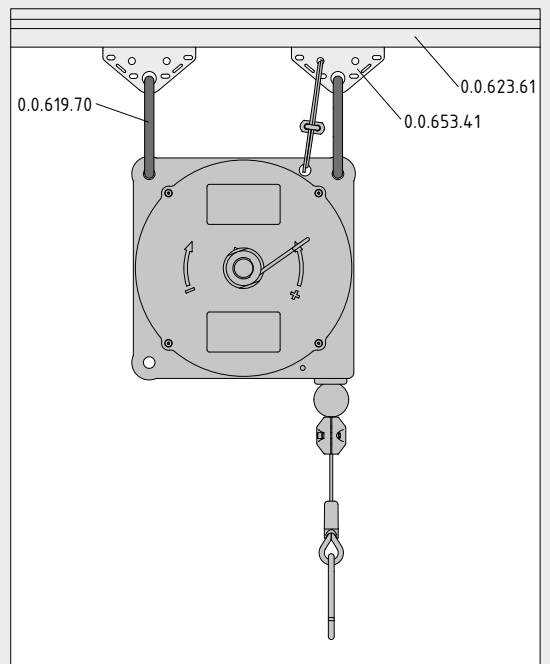



The following applies to all the sets below:

Casing

Steel cable Ø 2.5mm, St, stainless

Arrester mechanism: Steel cable Ø 2mm, St, stainless; steel cable clamp, St, bright zinc-plated

Spring hook, St

Wrench 30 A/F, St, bright zinc-plated

Notes on Use and Installation

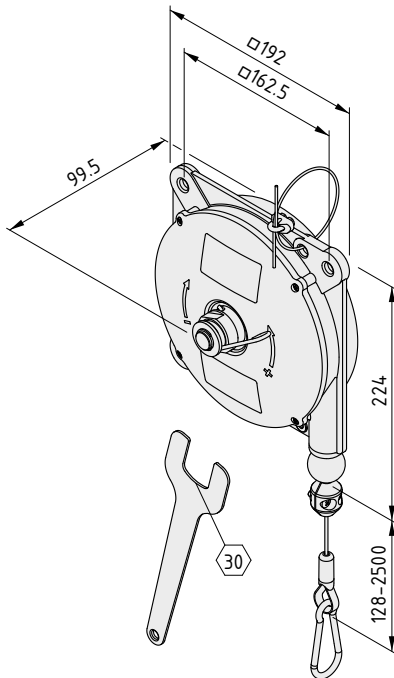

Tool Balancer 4-6 kg

m = 3.3 kg

1 set

0.0.674.95

Tool Balancer 6-8 kg

m = 3.4 kg

1 set

0.0.674.96

Tool Balancer 8-10 kg

m = 3.5 kg

1 set

0.0.674.97

Tool Balancer 10-14 kg

m = 3.8 kg

1 set

0.0.674.98

Bumper protection.

Absorbs collisions

Reduces wear on factory equipment

8 Corner Deflector Guard 8 St 160x160x80

Is the curve too tight or the wall too wide? There's no way of completely avoiding minor knocks and scrapes in intralogistics. The item Corner Deflector Guard 8 St 160x160x80, which is made of steel, acts like an integral bumper. It absorbs the impact so that the frame of the transport trolley isn't damaged.

The collision protection covers the outer edges because these are the most likely to be damaged when a trolley is being manoeuvred around bends. Maintenance outlay and wear are greatly reduced when the load-bearing profiles are protected from damage.



Installation examples showing Corner Deflector Guard 8 St 160x160x80 on basic constructions made of Line 8 profiles:

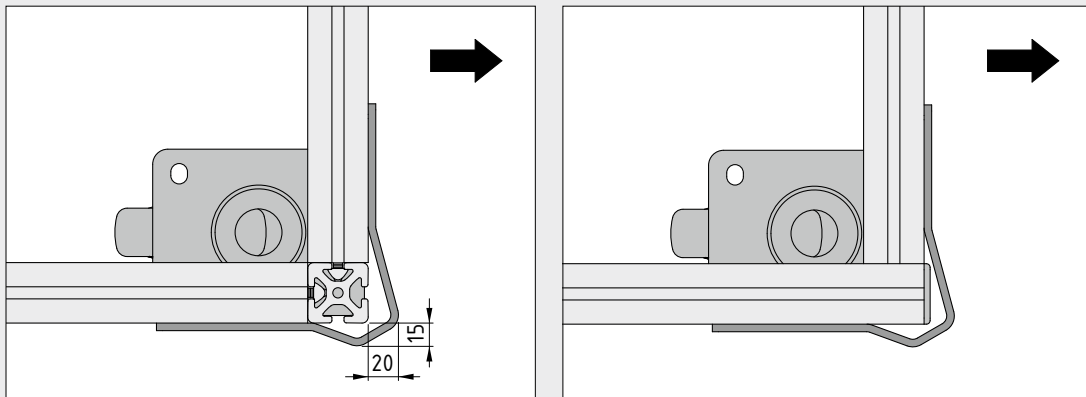

The fastening set for Corner Deflector Guard 8 St 160x160x80 consists of four double T-Slot Nuts, which ensure a secure hold and are easy to install. Because they are easier to align, the double T-Slot Nuts can be screwed into place much faster than single T-Slot Nuts.

Installation examples showing the Fastening Set for Corner Deflector Guard 8 St 160x160x80:

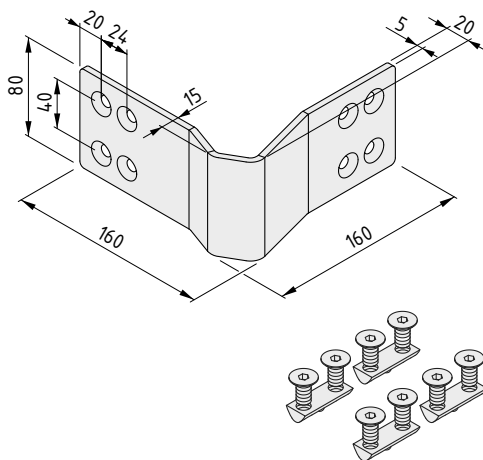
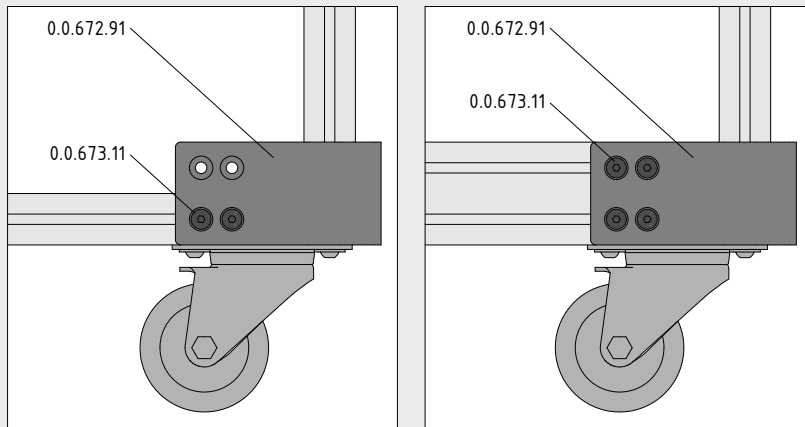

Corner Deflector Guard 8 St 160x160x80



St, bright zinc-plated
m = 934.0 g

1 pce.

0.0.672.91

Fastening Set for Corner Deflector Guard 8 St 160x160x80



4 T-Slot Nuts 8 St 2xM8-36, bright zinc-plated
8 Countersunk Screws DIN 7991 M8x16, St, bright zinc-plated
m = 124.0 g

1 set

0.0.673.11



Ergonomic production – with the item Work Bench System.

Divider and Guide Profile 32x12

Divider and Guide Profile 32x12, Connection Sets

Divider 600

Cantilever Foot Set 8 160x60-790x90

Double Cantilever Foot Set 8 160x60-1260x90

Profile 8 160x60 6N E

Table-Top Support Set 8 520x100

Installation Profile 160x80 1200, 1500, 1800

LED Light Set 30W

Back Stop Insert ESD

Lane assistant.

Simplified material picking

Easy width adjustment

Fits the item ergologic® Trays

Divider and Guide Profile 32x12
Divider and Guide Profile 32x12, Connection Sets
Divider 600

The perfect addition to full-width Trays 8 ESD A! The Dividers are used to separate the material restocking and removal positions for containers. The narrow and stable ribs ensure that semi-open fronted boxes, etc. are properly organised and lined up in the correct picking positions. When a work bench is reconfigured, the material picking system can be adapted in a few simple steps.

Divider and Guide Profile 32x12 is combined with the relevant Divider and Guide Profile 32x12, Connection Set to build dividing ribs in custom lengths. Please note that the Connection Sets are intended for use with different types of Tray edging (which Connection Set is required depends on whether the Tray has an all-round raised edge, one lowered edge or two lowered edges).

Divider 600 comes as a complete set suitable for Trays 8 ESD A in a standard depth of 600 mm. Designed for use with the three different Tray variants available in item ergologic®, the appropriate Dividers perfectly complement the ergonomic fusion of intralogistics and manual assembly processes.

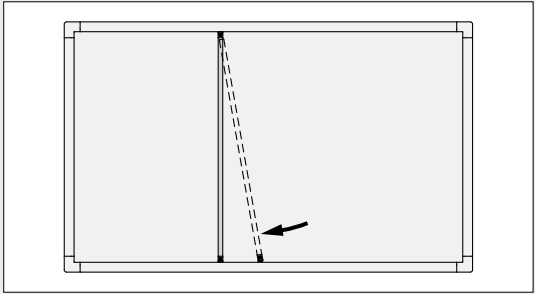

When fitted to Trays with an all-round raised edge, the Dividers are pivoted into place from the side.

The Divider and Guide Profile and the relevant Connection Set are used to build dividing ribs in custom lengths.

L_T = Length of Divider and Guide Profile

L_P = Length of profile

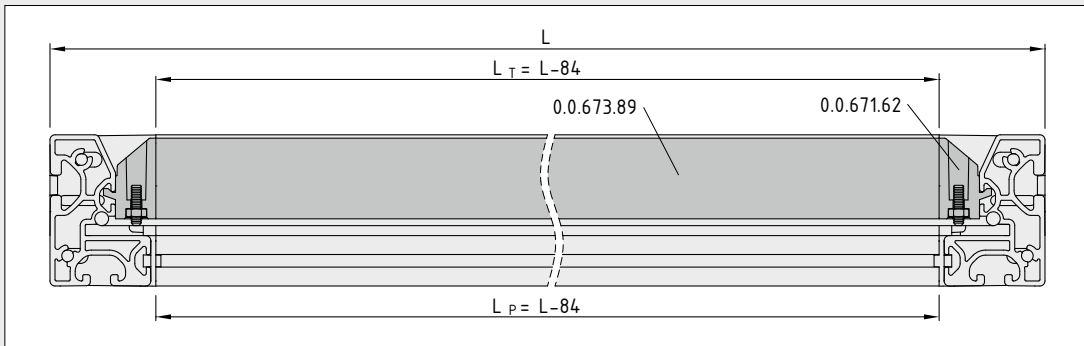

Divider

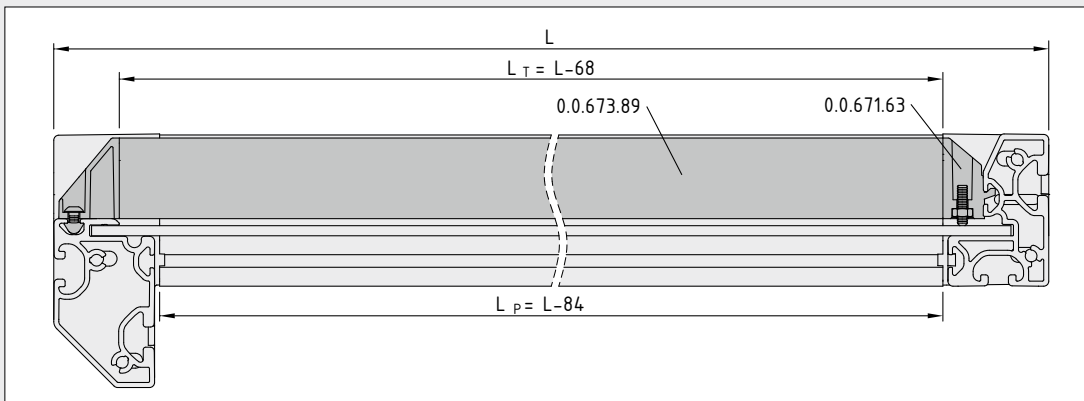

Divider 1x180°

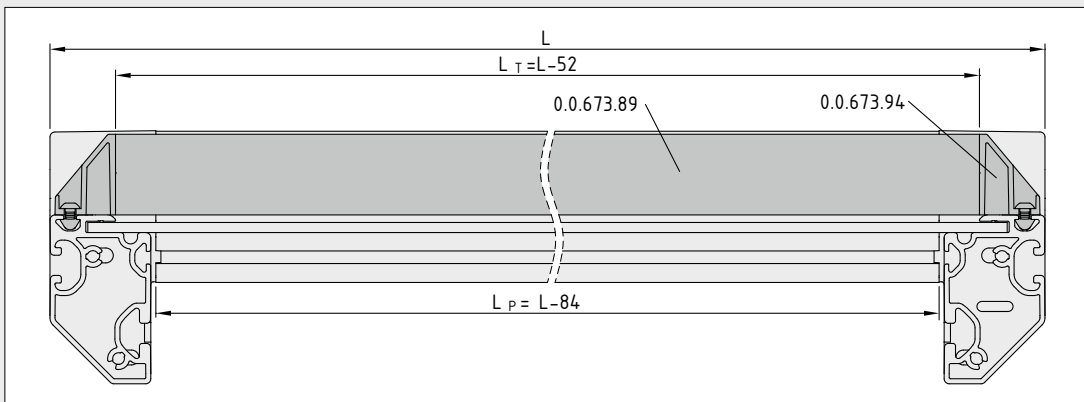

Divider 2x180°

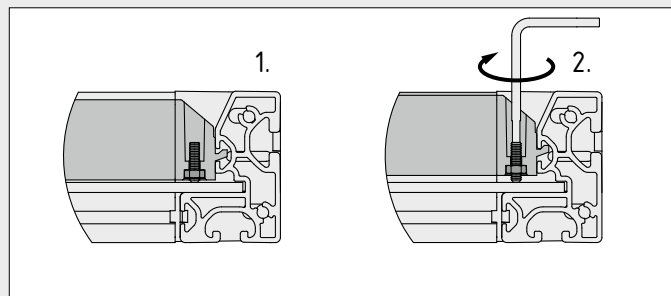
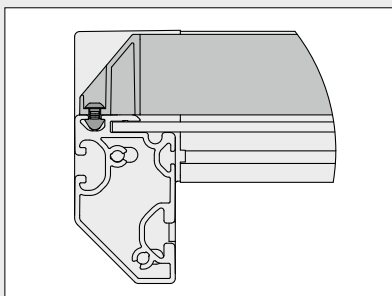

When using Trays with a lowered edge, Divider and Guide Profile 32x12, Connection Set 180° is fastened to the Frame Profile 8 60x40 using the T-Slot Nut included in the scope of supply.

When the grub screw is tightened, the Connection Set hooks into the groove on the raised edge because the divider is pushed up slightly.

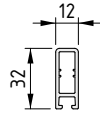

Divider and Guide Profile 32x12

Al, anodized
m = 420 g/m

natural, cut-off max. 6000 mm

0.0.673.89

natural, 1 pce., length 6000 mm

0.0.671.64

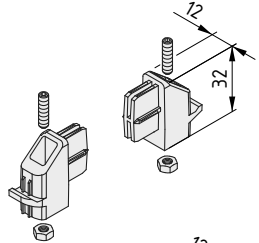

Divider and Guide Profile 32x12, Connection Set

2 Divider and Guide Profile 32x12 fasteners 0°, PA-GF, grey similar to RAL 7042
Fastening elements
m = 16.0 g

1 set

0.0.671.62

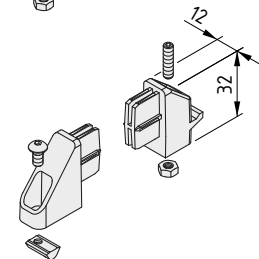

Divider and Guide Profile 32x12, Connection Set 1x180°

Divider and Guide Profile 32x12 fastener 180°, PA-GF, grey similar to RAL 7042
Divider and Guide Profile 32x12 fastener 0°, PA-GF, grey similar to RAL 7042
Fastening elements
m = 17.0 g

1 set

0.0.671.63

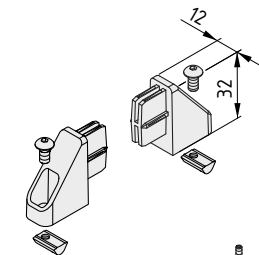

Divider and Guide Profile 32x12, Connection Set 2x180°

2 Divider and Guide Profile 32x12 fasteners 180°, PA-GF, grey similar to RAL 7042
Fastening elements
m = 17.0 g

1 set

0.0.673.94

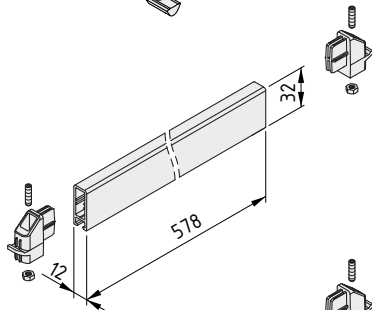

Divider 600

Divider and Guide Profile 32x12, Al
Divider and Guide Profile 32x12, Connection Set
m = 244.0 g

1 set

0.0.676.37

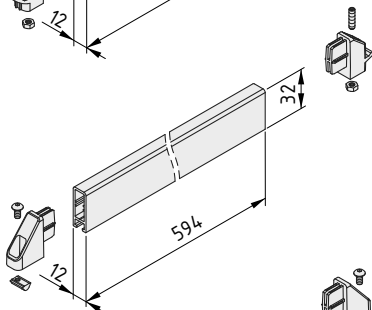

Divider 600 1x180°

Divider and Guide Profile 32x12, Al
Divider and Guide Profile 32x12, Connection Set 1x180°
m = 250.0 g

1 set

0.0.676.36

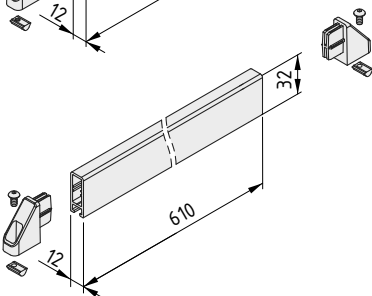

Divider 600 2x180°

Divider and Guide Profile 32x12, Al
Divider and Guide Profile 32x12, Connection Set 2x180°
m = 268.0 g

1 set

0.0.676.35



Upstanding.

Build customised tables

Economic material use

Compatible with the MB Building Kit System



Cantilever Foot Set 8 160x60-790x90
Double Cantilever Foot Set 8 160x60-1260x90
Profile 8 160x60 6N E
Table-Top Support Set 8 520x100

The specialists for custom work bench solutions! These components can be used to build reliable work benches while economising on materials.



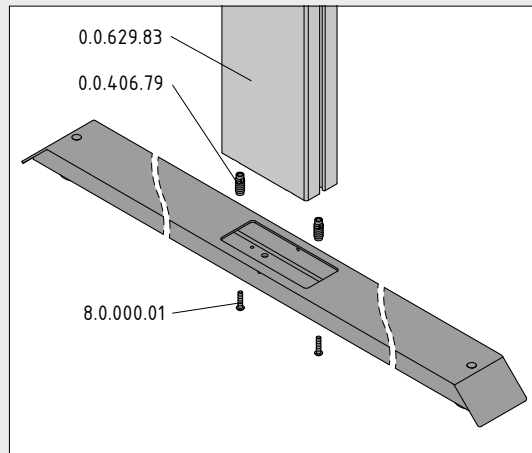
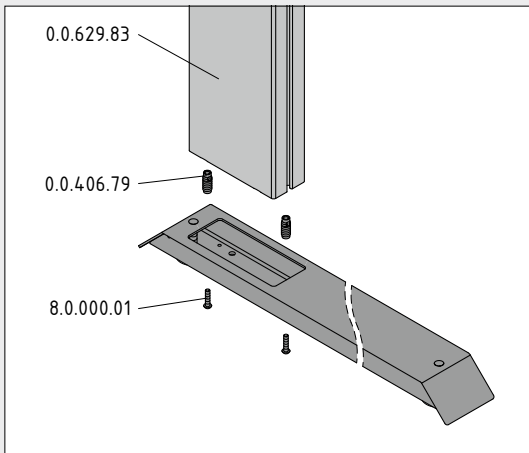
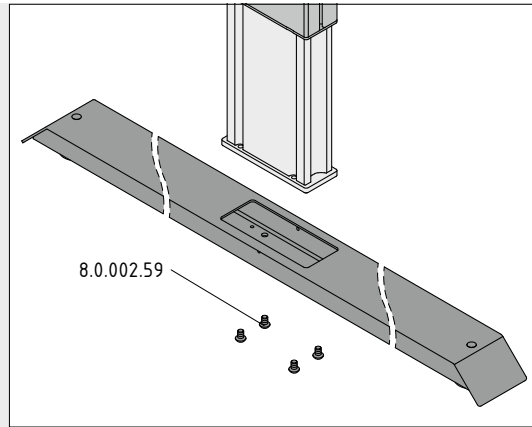
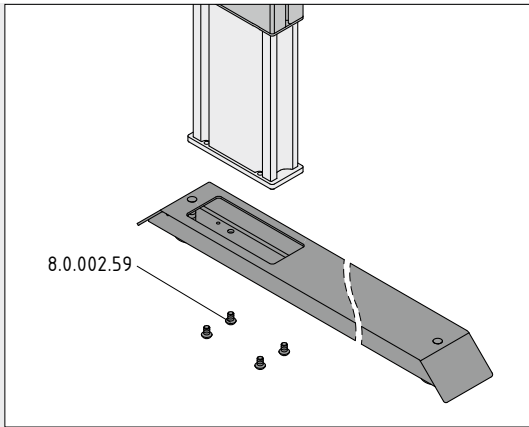

The item Cantilever Feet create a strong footing for work benches, their design ensuring stability even on benches with only two legs. As a result, users enjoy a great deal of legroom.

Cantilever Foot Set 8 160x60-790x90 is used to build individual benches. Double Cantilever Foot Set 8 160x60-1260x90 is used to support two back-to-back table tops mounted on just two central table legs.

Both Cantilever Feet can be combined with the electrically height-adjustable item Lifting Columns and the various Profiles 8 160x60. The necessary fixings for both applications are included in the scope of supply for the sets.

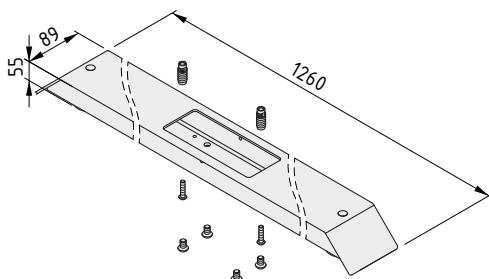
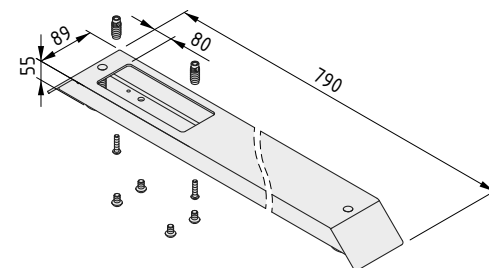

Cantilever Foot Set 8 160x60-790x90

2 table feet 160x60, St, powder-coated white aluminium similar to RAL 9006
Fastening elements
m = 10.1 kg

1 set 0.0.676.18

Double Cantilever Foot Set 8 160x60-1260x90

2 double table feet 160x60, St, powder-coated white aluminium similar to RAL 9006
Fastening elements
m = 15.8 kg

1 set 0.0.676.19



Profile 8 160x60 6N E creates strong table legs thanks to a cross-section that provides maximum torsion resistance for minimal weight. Suitable for use with the Cantilever Feet and featuring Line 8 system grooves, it opens up countless opportunities to exploit its compatibility with the MB Building Kit System to build custom table solutions.



Profile 8 160x60 6N E



Al, anodized

A [cm ²]	m [kg/m]	I _x [cm ⁴]	I _y [cm ⁴]	I _t [cm ⁴]	W _x [cm ³]	W _y [cm ³]
18.13	4.89	96.88	639.00	168.70	30.56	79.88
natural, cut-off max. 6000 mm						0.0.629.83
natural, 1 pce., length 6000 mm						0.0.629.81



Table-Top Support Set 8 520x100 is used to fasten table tops in place. It comprises two solid supports in compact dimensions that offer fastening options for the table legs, the table top and supporting struts on large work benches.

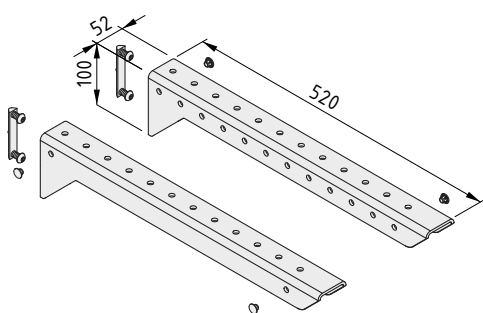

Table-Top Support Set 8 520x100

Table-Top Support right, St, powder-coated white aluminium similar to RAL 9006

Table-Top Support left, St, powder-coated white aluminium similar to RAL 9006

Fastening elements

m = 4.4 kg

1 set	0.0.676.17
-------	------------

All inclusive.

Cable conduit and compressed-air conduits

Direct installation of switches

Complete sets for work benches

8 Installation Profile 160x80 1200, 1500, 1800

Staying well supplied at the work bench! The Installation Profile 160x80 can be used to route all supply lines and cables safely to exactly where they are needed at the work bench. The complete sets include the Profile with integrated cable conduit and dual compressed-air conduit, Cover Profile and fixings.

Users can fit plug sockets and switches directly to the cable conduit of this load-bearing profile for tables in the standard widths of 1200 mm, 1500 mm and 1800 mm. Simply clip the Mounting Box into place – job done! Face Plates M45 with Labelling Panel, Horizontal can be used with the profile. Pneumatic Connecting Set 8 80x40 G1/2 allows users to connect to a compressed air supply.

Note: Installation Profile 8 160x80 K76 is available in custom lengths as a separate cable conduit. Detailed information, including technical drawings for Installation Profile 8 160x80 K76 and additional accessories such as Face Plates and Pneumatic Connecting Sets can be found starting on page 10.



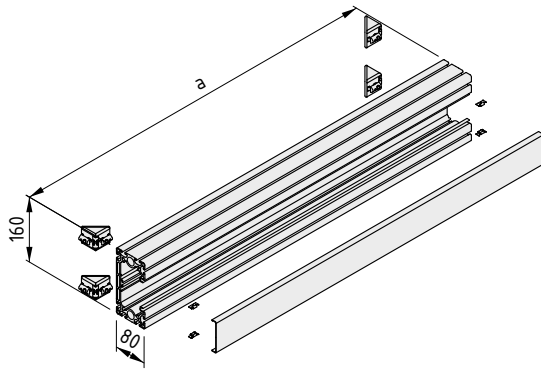

Installation Profile 160x80 1200



Installation Profile 8 160x80 K76, Al
 Cover Profile 76K, Al
 Installation Profile 160x80 Assembly Set
 a = 1,080 mm m = 9.5 kg

1 set 0.0.676.11

Installation Profile 160x80 1500



Installation Profile 8 160x80 K76, Al
 Cover Profile 76K, Al
 Installation Profile 160x80 Assembly Set
 a = 1,380 mm m = 12.0 kg

1 set 0.0.676.12

Installation Profile 160x80 1800



Installation Profile 8 160x80 K76, Al
 Cover Profile 76K, Al
 Installation Profile 160x80 Assembly Set
 a = 1,680 mm m = 14.4 kg

1 set 0.0.676.13

Enlightening.

The all-in-one LED package

Includes Light Fitting, Transformer and Cable

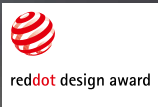

LED Light Set 30W

Everything that you need to bring light to the work bench! LED Light Set 30W combines the energy-saving item LED Light Fitting 30W with the corresponding Transformer and all the Connecting Cables to create a set that is ready to install.

The award-winning design of the LED Light Fitting, which features a diffusor panel and parabolic reflector grid, ensures that light is distributed evenly and without any glare. It is the perfect basis for supporting fatigue-free and efficient working practices.

The LED Light Fitting features an ON/OFF switch with integrated two-stage dimming.

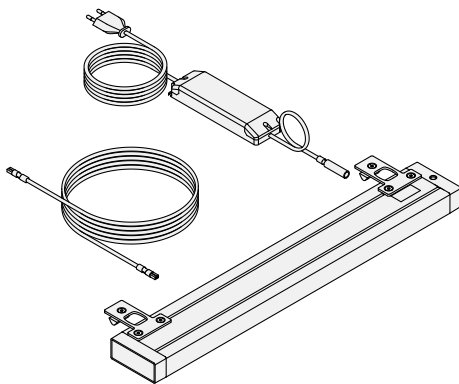

LED Light Set 30W



LED Light Fitting 30W
 Electronic Transformer LED 30W 24V
 Connecting Cable, LED Light Fitting
 m = 2.0 kg

1 set

0.0.676.14

No way back.

Control the direction of travel

Can be retrofitted

For Castor Rail 8 40x40



Back Stop Insert ESD

Make sure Castor Rail 8 40x40 has just one objective! Back Stop Insert ESD lets containers and goods pass in one direction only. When work benches are interlinked, including in one-piece-flow scenarios, this insert ensures that work-piece carriers and containers stick to the specified route. When used on mobile material supply equipment, the insert acts as a transport securing device.

Back Stop Insert ESD is compatible with the modular Castor Rail 8 40x40 and, like the other Inserts that are available, can also be retrofitted by simply being clipped into place – no tools required. The Back Stop is ESD-safe as standard.

Note: Back Stop D2.8-25 (0.0.666.67) is used for Roller Conveyor St D30 (0.0.633.91). Back Stop D4-23 (0.0.659.05) is used for Roller Conveyor 6 40x40 E D30 (0.0.658.69).

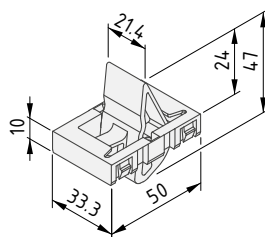
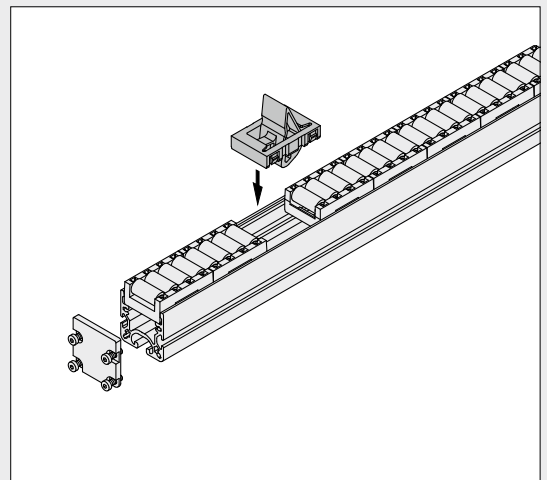

Back Stop Insert ESD

Housing, PA-GF, black
Back Stop D4-23, PA-GF, black
Axle, St, stainless
m = 19.0 g

1 set



0.0.675.98



Build lean – with the Lean Production Building Kit System.

Roller Conveyor St 60x24 D15

Fastening Profile D30-60

Guide Rail e 4

Button-Head Screw Self-Tapping M5x16, TX25

Roller Conveyor 60 Fastening Brackets D30

Braking Castor D30-23

Roller D46/D30-20 ESD

Fastening Ring D40/D30-10 ESD

Threaded Inserts, Profile Tube D30 heavy duty

Ball Joint Butt Fastener D30

Tube D30x1.5 CFRP



Made to measure.

Space saving

Flexible configuration

Robust and flat



Roller Conveyor St 60x24 D15

The robust roller conveyor for all scenarios! Thanks to its wide rollers and low roller diameter, Roller Conveyor St 60x24 D15 is compatible with most installation scenarios and transported goods – even crates and goods with awkward bases. As such, it is a perfect addition to the Lean Production Building Kit System.

Fixing it to a frame couldn't be easier: Roller Conveyor 60 Fastening Bracket D30 is used to create a connection with the frame at the start and end of a roller conveyor. Roller Conveyor 60 Fastening Bracket D30 with Stop H43 is used as a stop at the end of a Roller Conveyor St 60.

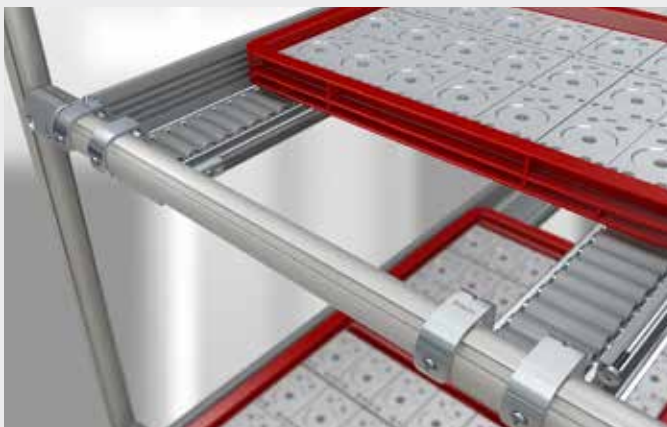

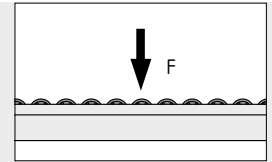
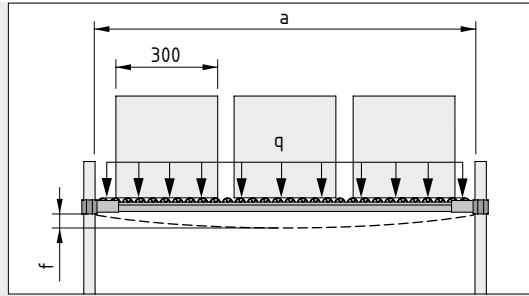
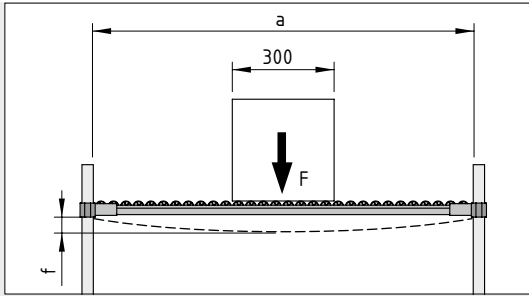

Permissible force on a single roller of Roller Conveyor St 60x24 D15: $F < 100 \text{ N}$

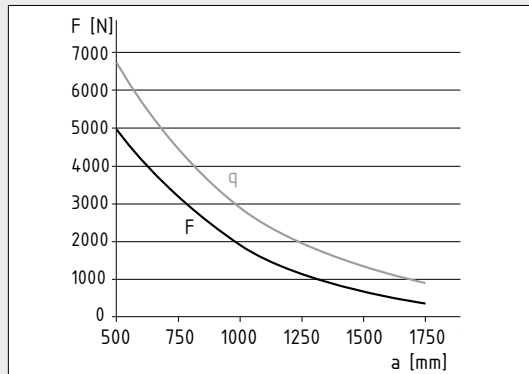
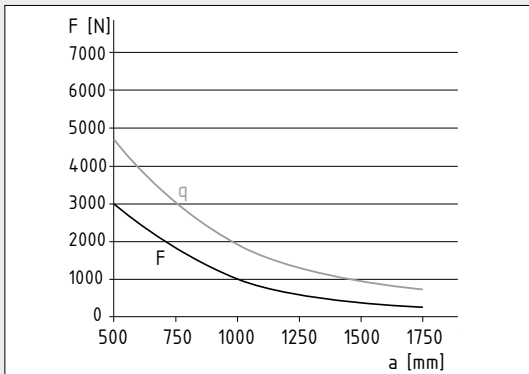

Load specifications for two parallel Roller Conveyors. Maximum recommended profile deflection: $f < 1/100 a$

Caution:
Note the maximum load-carrying capacity of the components involved.

Roller Conveyor St 60x24 D15

The additional use of Fastening Profile D30-60 increases resistance to profile deflection. Permissible load increases by 20 percent compared to the diagram.

Roller Conveyor St 60x24 D15

Roller Conveyor St 60x24 D15 with Fastening Profile D30-60 and Guide Rail e 4

Recommended load on Roller Conveyor St 60x24 D15 with Fastening Profile D30-60 and Guide Rail e 4.

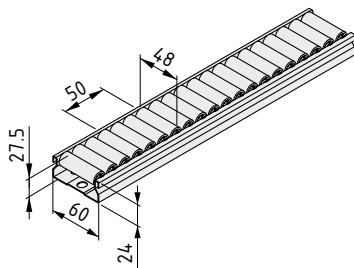

Roller Conveyor St 60x24 D15

St, bright zinc-plated
Rollers PP, grey
Axles St, bright zinc-plated
 $m = 1.53 \text{ kg/m}$

cut-off max. 4500 mm 0.0.673.74

1 pce., length 4500 mm 0.0.670.87

Roller Conveyor St 60x24 D15, ESD



St, bright zinc-plated
Rollers PP, black
Axles St, bright zinc-plated
 $m = 1.53 \text{ kg/m}$

cut-off max. 4500 mm 0.0.673.75

1 pce., length 4500 mm 0.0.673.73



Supporter.

For fastening Guide Rails

Boosts the rigidity of Roller Conveyor St 60

Additional frame-fixing option

Fastening Profile D30-60

This profile keeps things connected! Fastening Profile D30-60 is used to fit a guide rail to Roller Conveyor St 60x24 D15. The roller conveyor is simply slotted or clipped in. Fitting Guide Rail e 4, which is anchored in the special flat groove along the side, makes the roller conveyor more rigid.

The Guide Rail can run right up to the cross tube, thereby minimising the gap at crossing points. A Profile Tube D30 contour runs along the underside of Fastening Profile D30-60 and can be used to make a connection with struts and accessories.



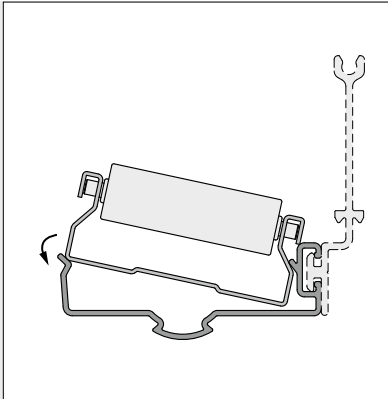

Roller Conveyor St 60x24 D15 can be pressed into Fastening Profile D30-60 using a little force or can be slotted into place during assembly.

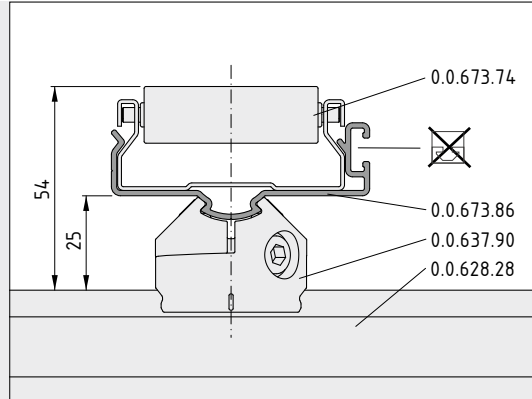

If necessary, Roller Conveyor St D60x24 D15 can be reinforced against profile deflection with the aid of Fastening Profile D30-60.

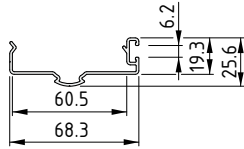

Fastening Profile D30-60

Al, untreated
m = 0.44 kg/m

natural, cut-off max. 6000 mm	0.0.673.86
natural, 1 pce., length 6000 mm	0.0.673.85



Guideline.

A reliable railing for Roller Conveyor St 60

Guide Rail e 4 Button-Head Screw Self-Tapping M5x16, TX25

Keeping everything in line! Robust Guide Rail e 4 ensures that crates and goods stay on Roller Conveyor St 60x24 D15. Fastening Profile D30-60 is used to install the Guide Rail. The aluminum Guide Rail e 4 is inserted into the special groove that runs along the side of the Fastening Profile. This combination of Guide Rail and Fastening Profile boosts the rigidity of the roller conveyor.

When Guide Rails e 4 are cut to size, sharp edges on the channel at the top can present an injury hazard for personnel loading and unloading the roller conveyor. The quickest way to eliminate this hazard is to use Button-Head Screw Self-Tapping M5x16, TX25! It quickly and reliably makes the end of the channel safe, without having to spend time manually deburring it, thus lowering assembly costs.



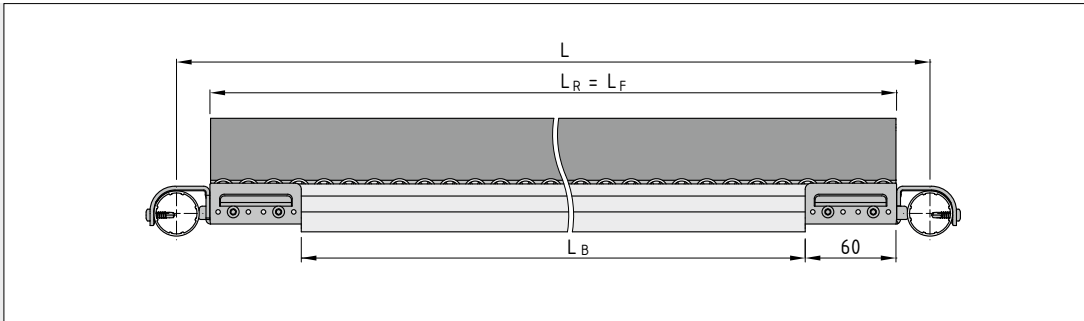

L_R = Roller Conveyor
 L_F = Guide Rail
 L_B = Fastening Profile

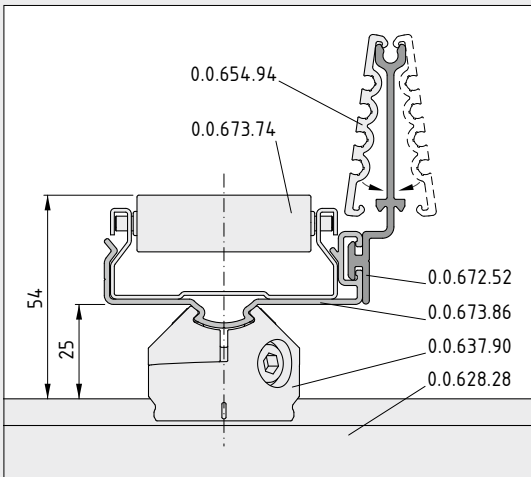
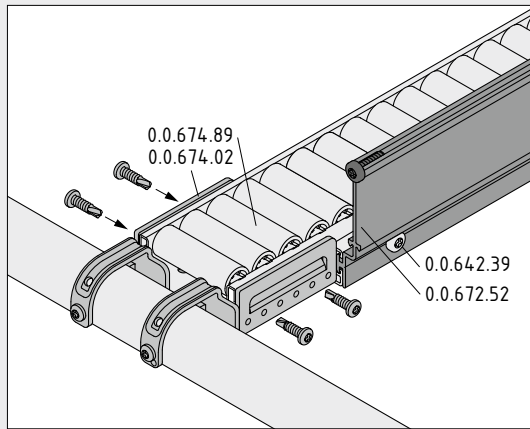
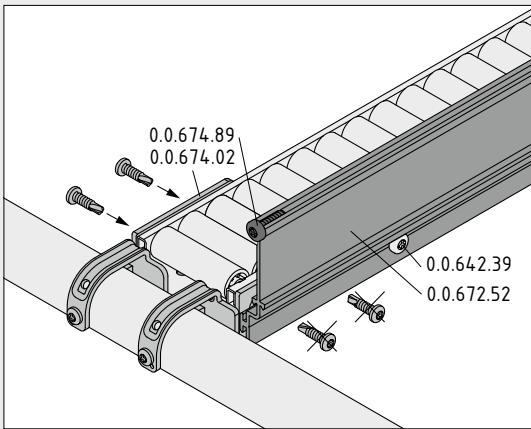

If necessary, Roller Conveyor St D60x24 D15 can be reinforced against profile deflection with the aid of Fastening Profile D30-60.

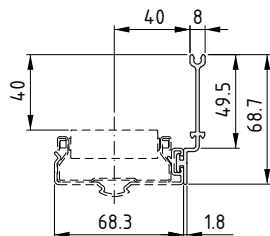

Guide Rail e 4

Al, untreated
 $m = 0.51 \text{ kg/m}$

natural, cut-off max. 6000 mm	0.0.672.52
natural, 1 pce., length 6000 mm	0.0.672.51

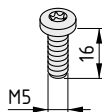

Button-Head Screw Self-Tapping M5x16, TX25

St
 $m = 4.0 \text{ g}$

bright zinc-plated, 1 pce.	0.0.674.89
----------------------------	------------



One for all.

Strong and secure

Simple transitions

Roller Conveyor 60 Fastening Bracket D30 Roller Conveyor 60 Fastening Bracket D30 with Stop H43

Secure hold and optimum extendibility in one! Roller Conveyor 60 Fastening Bracket D30 creates a connection with the frame at the start and end of a Roller Conveyor St 60x24 D15. Thanks to the asymmetrical arrangement of the hooks, two Fastening Brackets can be fixed to the same Tube to create level or angled conveyor lines. This reduces the number of different parts that are required, which benefits stockkeeping.

Roller Conveyor 60 Fastening Bracket D30 with Stop H43 can be used to bring containers safely to a stop at the end of Roller Conveyor St 60x24 D15. The raised stop secures crates and prevents them slipping out of the roller conveyor.

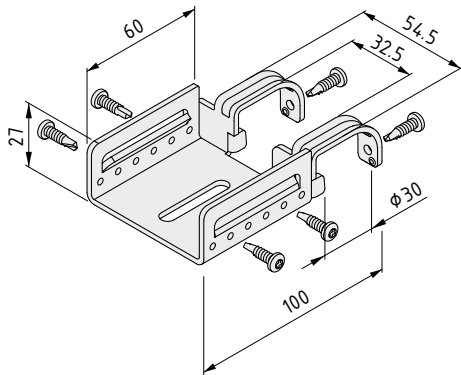

Roller Conveyor 60 Fastening Bracket D30

St, bright zinc-plated
 6 Button-Head Screws, self-tapping St, 3.9x16, TX20, bright zinc-plated
 m = 174.0 g

1 set	0.0.674.02
-------	------------

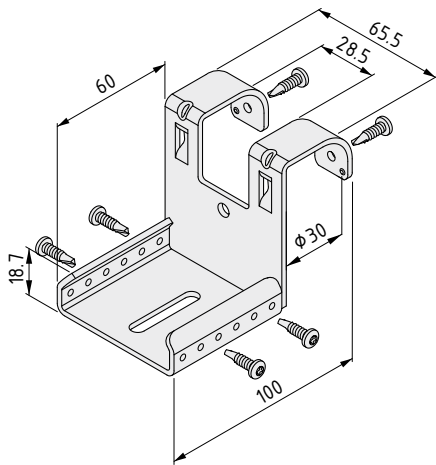

Roller Conveyor 60 Fastening Bracket D30 with Stop H43

St, bright zinc-plated
 6 Button-Head Screws, self-tapping St, 3.9x16, TX20, bright zinc-plated
 m = 231.0 g

1 set	0.0.674.03
-------	------------



Always ready to brake.

Regulates speed

Adaptive braking action

Can be replaced without tools

Braking Castor D30-23

The insert for controlling speed on the roller conveyor! Since crates and goods glide over a roller conveyor at high speed, it can sometimes be necessary to intervene at specific points to prevent heavy impacts and thus reduce strain on the frame and the transported goods.

Braking Castor D30-23 regulates speed on the rigid aluminium Roller Conveyor 6 40x40 E D30 (0.0.658.69). When objects are moving slowly, the mechanical system has a lower braking effect. Braking Castors keep things moving at a consistent speed, even on steep gradients and when working with heavy objects.

While a roller conveyor brake is fitted at the end of the line, Braking Castors are spread out along the entire length of a roller conveyor. There are two benefits to this: Firstly, it is an effective way to stop transported goods from building up too much speed. Secondly, it does not compromise automatic unloading on a FIFO rack or Karakuri solution, because the lower-most containers are stored on moving roller elements and can start moving again.

The item Braking Castor can also be retrofitted to existing conveyor lines without needing any special tools, making it easy to install it in the optimum position for the relevant application. It is also just as easy to change the position of the Braking Castor or replace it.

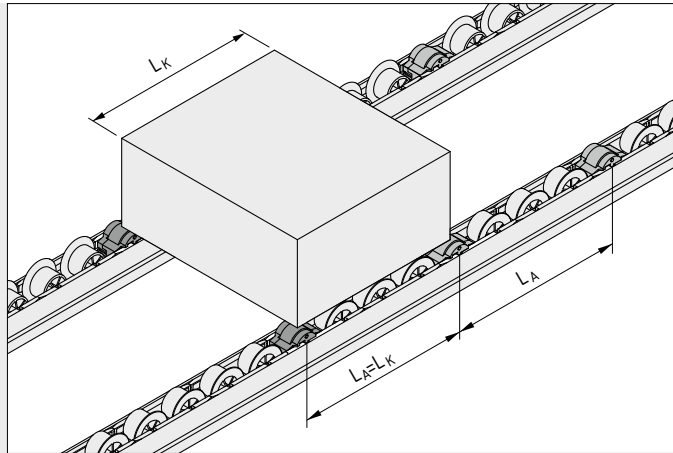
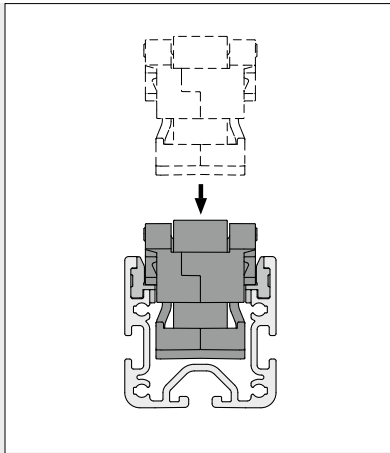

L_A = Spacing of Braking Roller

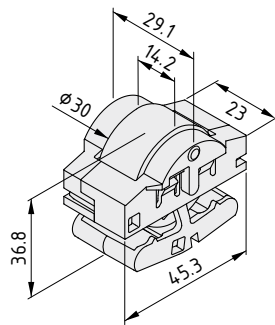

Braking Castor D30-23

PA/TPE

4 Dowel Pins 6x20, St, bright zinc-plated

m = 35.0 g

grey similar to RAL 7042, 1 pce.

0.0.670.90



Keep them rolling.

Supports movement

Protects profiles

Now also ESD-safe



Roller D46/D30-20 ESD Fastening Ring D40/D30-10 ESD

The helpful Roller now available in an electrostatically dissipative version! Roller D46/D30-20 ESD uses a D30 profile as an axis. It guides crates and goods safely through the frame and protects the containers and profile at the same time. If necessary, its vertical or horizontal position can be fixed using Fastening Ring D40/D30-10 ESD.

Roller D46/D30-20 ESD is used to provide side guidance (e.g. in Karakuri applications) or to support crossing points on roller conveyors. As it has the same conveying height as the item roller conveyors, the Roller can be installed between angled sections of roller conveyor by being mounted directly to the same support profile that the Roller Conveyor Fastening Brackets are fixed to. This further reduces the gap and ensures gentler, more reliable travel.

Roller D46/D30-20 ESD rotates on a Tube D30 or Profile Tube D30 and does not need to be lubricated. Static charges generated by friction on the plastic roller are dissipated through the profile.

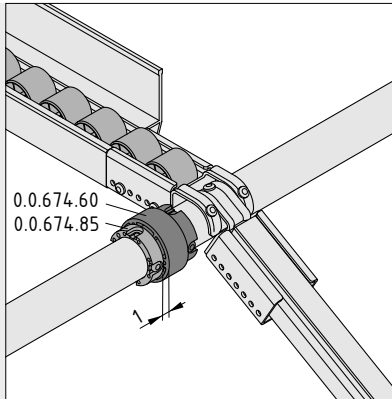

Rollers D46/D30-20 ESD and Fastening Rings D40/D30-10 ESD must be pushed onto the (Profile) Tube D30 before the tube is fitted into place.

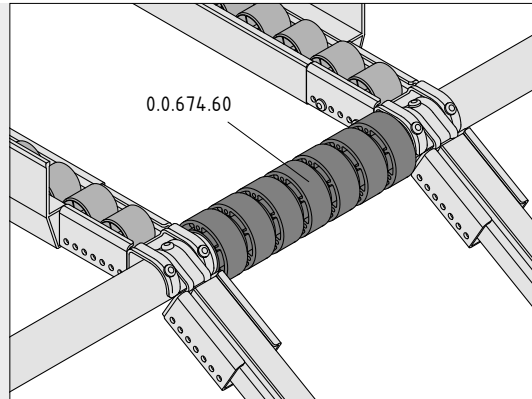

Several Rollers can be used alongside each other to create a broader rolling surface.

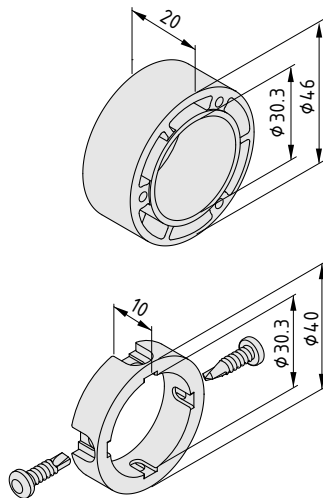

Roller D46/D30-20 ESD



PA
m = 13.0 g

black similar to RAL 9005, 1 pce.

0.0.674.60

Fastening Ring D40/D30-10 ESD



Fastening Ring D40/D30-10 ESD, PA, black
2 Button-Head Screws self-tapping St 3.9x16, TX20, bright zinc-plated
m = 6.0 g

1 set

0.0.674.85

A close-up photograph of a silver-colored metal profile tube with a threaded insert. The insert is a circular, self-tapping component with a central threaded hole. The tube has a complex, multi-faceted shape. A red banner is overlaid on the top right, and three red banners with white text are on the left side.

The heavy weight.

Thread for high tensile loads

Strong and stable

For Profile Tube D30 heavy duty

Threaded Insert, Profile Tube D30 heavy duty M8 Threaded Insert, Profile Tube D30 heavy duty M10

More options for the especially strong Profile Tube D30 heavy duty! The self-tapping item Threaded Insert is now also available for M8 and M10 threads. Whether for connecting Adjustable Feet or fixing accessories to the end face of the profile, Threaded Insert, Profile Tube D30 heavy duty M8 and Threaded Insert, Profile Tube D30 heavy duty M10 create a mechanically locked connection that can accommodate exceptionally high compressive and tensile loads.

Threaded Insert, Profile Tube D30 heavy duty M12 (0.0.648.64) is still available for heavy-duty fixtures that use M12 bolts.

When working with Tubes D30 and Profile Tubes D30 that have the standard wall thickness, use Threaded Inserts D30 with the relevant thread size.



Threaded Inserts, Profile D30 heavy duty are very easy to screw into the end face of the Profile D30.

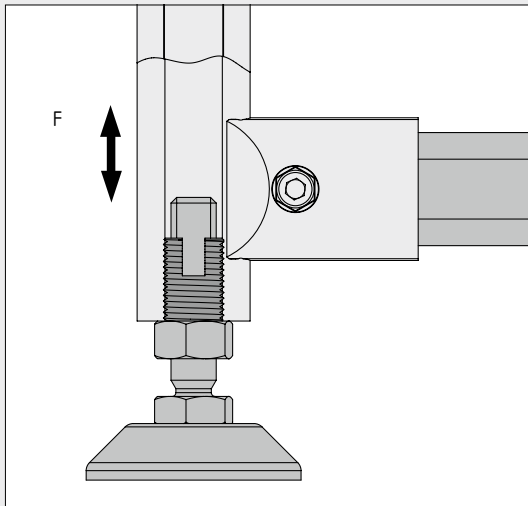

$F_{\max} = 20.000 \text{ N}$

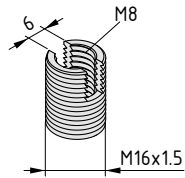

Threaded Insert, Profile Tube D30 heavy duty M8

St

m = 18.6 g

bright zinc-plated, 1 pce.

0.0.672.18

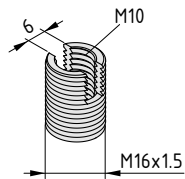

Threaded Insert, Profile Tube D30 heavy duty M10

St

m = 15.4 g

bright zinc-plated, 1 pce.

0.0.672.19

Free spirit.

For any angle

Quick to fit

Ball Joint Butt Fastener D30

Perfect for custom transport trolleys! Ball Joint Butt Fastener D30 connects the end faces of two Profiles D30 at any angle. Thanks to the stable internal ball, users can twist and turn the fastener 180° to the desired position and fix it in place with a single screw.

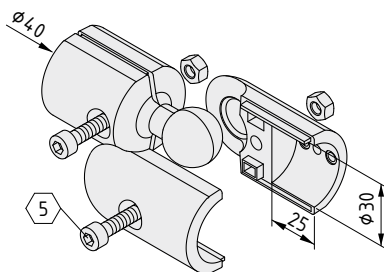
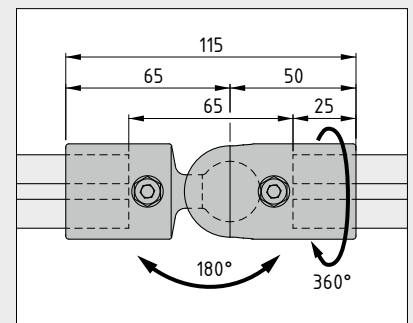

Ball Joint Butt Fastener D30

2 ball joint fastener halves, ball head with profile fixture, die-cast aluminium, natural
 2 ball joint fastener halves, ball socket with profile fixture, die-cast aluminium, natural
 2 Hexagon Socket Head Cap Screws DIN 912-M6x28, St, bright zinc-plated
 2 washers, St, bright zinc-plated
 2 hexagon nuts DIN 934-M6, St, bright zinc-plated
 m = 219.0 g

1 set

0.0.671.72

Carbonara.



Tube D30 made from carbon

Light and extremely strong

High-end look

Tube D30x1.5 CFRP

Minimum weight, maximum strength! Extremely torsion-resistant Tube D30x1.5 CFRP supports weight-optimised applications. The high-strength carbon tube weighs around 40 percent less than a Tube D30 made of aluminium – which is already light to start with. Its low dead weight makes it ideal for building dynamic Karakuri assemblies. Structures mounted on handling devices and robots also benefit from the combination of low mass moment of inertia and high torsion resistance.

The anthracite-coloured tube is also very attractive. Using high-quality Tube D30x1.5 CFRP enhances the value of constructions.

Note: Health and safety guidelines for the machining of CFRP materials (e.g. DGUV regulations in Germany) should be taken into account when carrying out machining work. For perfect results, item recommends ordering Tubes that have already been cut to size.



Tube D30x1.5 CFRP
CFRP

A [cm ²]	m [kg/m]	I _x [cm ⁴]	I _y [cm ⁴]	I _z [cm ⁴]	W _x [cm ³]	W _y [cm ³]	
1.34	0.24	1.37	1.37	2.73	0.91	0.91	
anthracite, cut-off max. 6000 mm						0.0.644.75	
anthracite, 1 pce., length 6000 mm						0.0.644.74	



Other item product catalogues.

MB Building Kit System

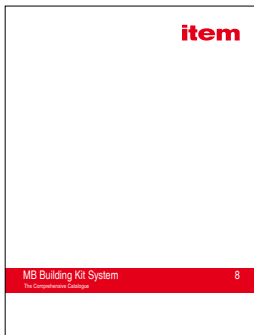

item24.de/en/epaper-mb

Line XMS



item24.de/en/epaper-xm

Work Bench System



item24.de/en/epaper-wbs

Lean Production Building Kit System



item24.de/en/epaper-lp

Stairway/Platform System



item24.de/en/epaper-tp

Automation System

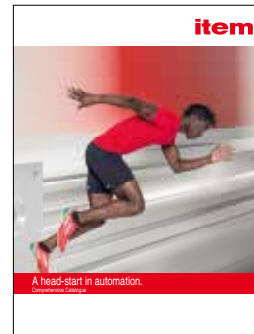

item24.de/en/epaper-au



All the information you need at your fingertips

item product catalogues are available online as clearly laid out and convenient e-papers. Take your pick and get browsing!



Stay in the loop, even when you're offline.

Simple planning without the Internet: item ikasys provides all the product information you need, including installation guides and CAD data, on a DVD.

Your head-start for know-how – the item online portfolio.



Service and information around the clock – item24.com.

item is always there for you! You can find all the product information you could need on the item website – including CAD data. You will also discover the very latest news and a whole range of example applications. Complete parts lists and 3D PDFs provide the ideal basis for your own planning. What's more, you can access an entire media library, discover service offerings and get in touch with item – all at the click of a mouse.

item24.com

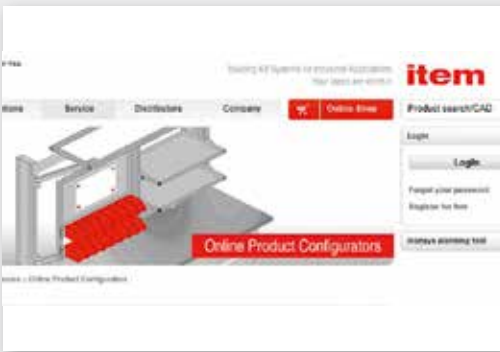

Plan fast and make the right decisions – the item online tools.

You can count on us! The item Online Product Configurators and online tools such as the Deflection Calculator for profiles will save you a lot of time. State-of-the-art planning aids for work benches and SystemMobiles make it much easier for you to configure the perfect bespoke solution. When it comes to automation, you can track down the ideal Linear Unit using the Product Finder for linear technology. And the Query Assistant is ideal for helping you plan stairways and platforms with ease.

item24.de/en/configurators



See how it's done – with item on YouTube.

They say a picture is worth more than 1000 words. So – at 25 images per second – you can imagine just how informative the item videos are. You can find assembly tips and useful information, all packaged up in moving images, on YouTube. Specialists also answer frequently asked questions relating to issues such as ergonomics and lean production. Tune in to the item channel and make the most of our comprehensive catalogue of videos.

youtube.com/item24com

Alphabetical Register.

B

Back Stop Insert ESD	32
Ball Joint Butt Fastener D30	48
Banjo Connector G1/2 for Hose 9 mm	16
Base Plate, Installation Profile 160x80	10
Braking Castor D30-23	42
Button-Head Screw Self-Tapping M5x16, TX25	38

C

Cantilever Foot Set 8 160x60-790x90	26
Cap 6 D11	7
Cap 8 160x160 St	13
Cap 8 160x80 St	13
Cap 8 80x16 Zn	6
Corner Deflector Guard 8 St 160x160x80	20

D

Divider 600	23
Divider and Guide Profile 32x12	23
Divider and Guide Profile 32x12, Connection Sets	23
Double Cantilever Foot Set 8 160x60-1260x90	26

F

Face Plates M45 with Labelling Panel, Horizontal	14
Fastening Profile D30-60	36
Fastening Ring D40/D30-10 ESD	44
Fastening Set for Corner Deflector Guard 8 St 160x160x80	20

G

Guide Rail e 4	38
----------------	----

I

Installation Profile 160x80	29
Installation Profile 8 160x80 K76	10

L

LED Light Set 30W	31
-------------------	----

P

Pneumatic Connecting Set 8 80x40 G1/2	16
Profile 8 120x40 3N light	5
Profile 8 80x40 3N90 light	5

R

Roller Conveyor 60 Fastening Bracket D30	40
Roller Conveyor 60 Fastening Bracket D30 with Stop H43	40
Roller Conveyor St 60x24 D15	34
Roller D46/D30-20 ESD	44

S

Screw Plug with Shoulder G1/2	16
Sealing Plug D19	16
Security Bit Set 2A/F - 6A/F	9
Spanner 65A/F / 17A/F flat	8

T

Table-Top Support Set 8 520x100	26
Threaded Insert, Profile Tube D30 heavy duty M10	46
Threaded Insert, Profile Tube D30 heavy duty M8	46
Tool Balancer 10-14 kg	18
Tool Balancer 4-6 kg	18
Tool Balancer 6-8 kg	18
Tool Balancer 8-10 kg	18
Tube D30x1.5 CFRP	49

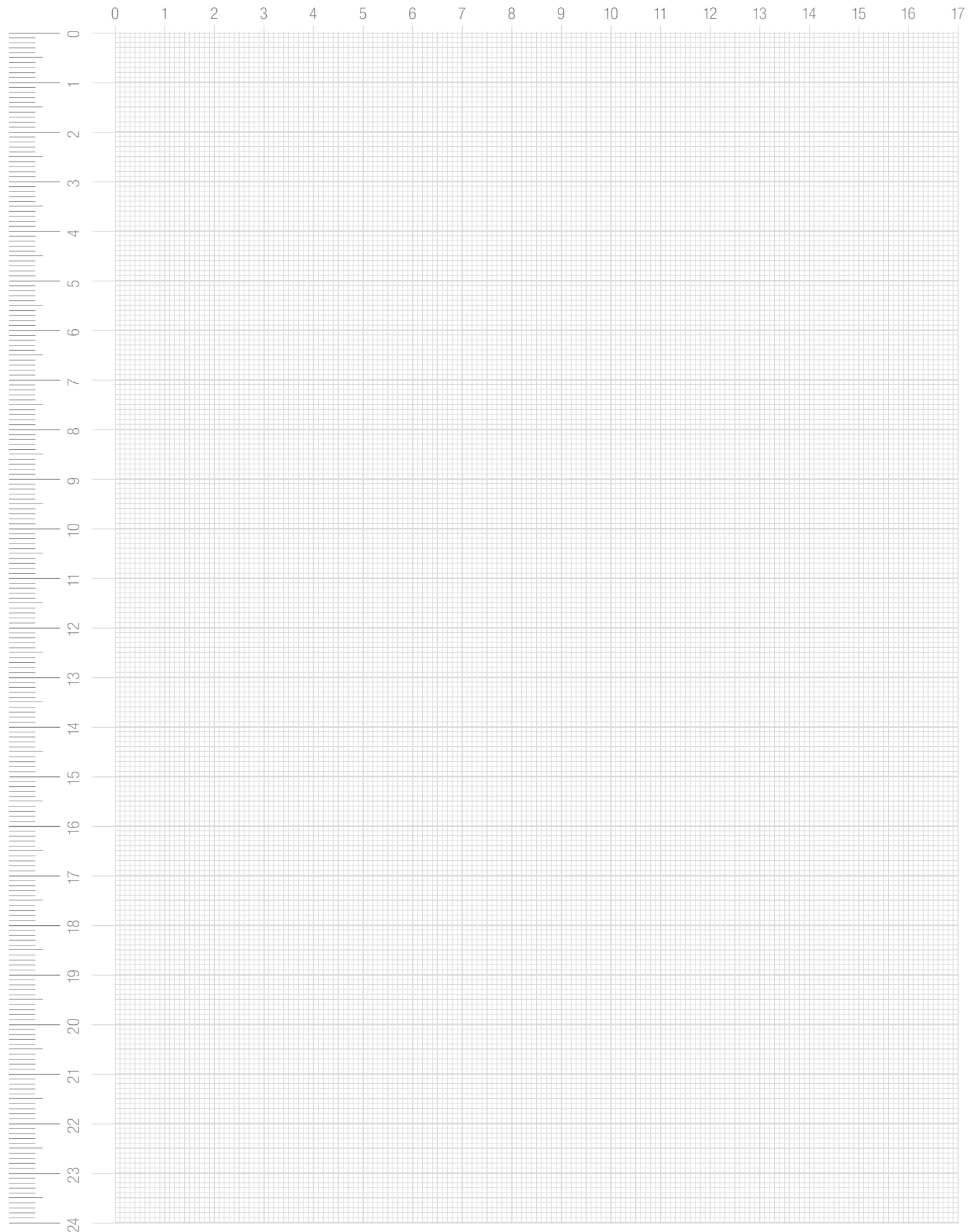

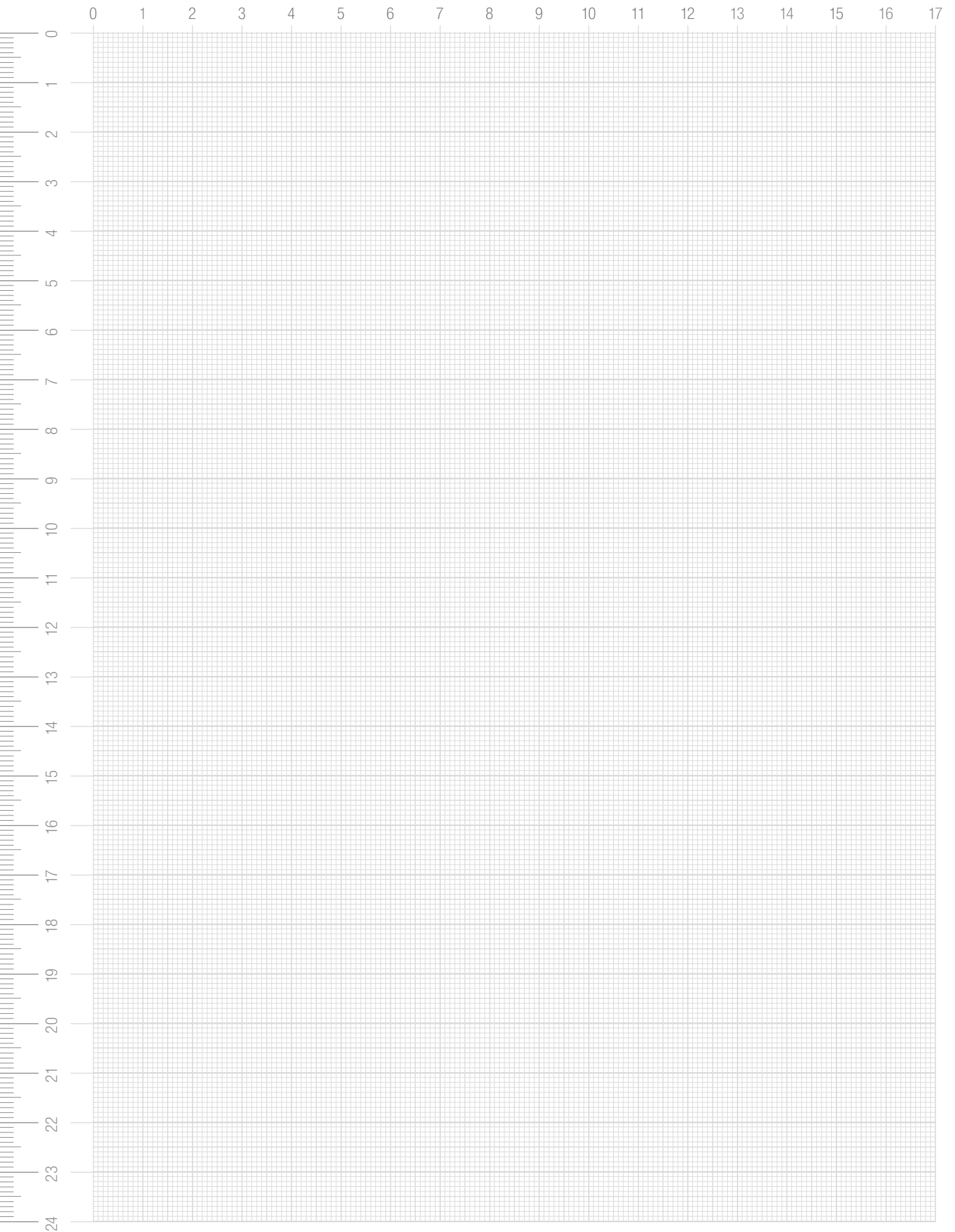



Always there for you.

Always up to date: Our website at item24.com offers further information on all the products and technologies that item supplies.

Patents

Any copying of protected products is a violation of rights and, as such, shall be liable to compensation. Data and illustrations in this catalogue do not discharge the user from the obligation to carry out his own checks to determine whether the industrial property rights of third parties are infringed.

Product liability

item shall be liable, within the framework of the applicable legal provisions, for the promised characteristics of the products shown in this catalogue. Any claims for liability above and beyond such – in particular relating to products created by third parties using products included in this catalogue – are expressly excluded.

Conditions of use

The products in the item MB Building Kit System are suitable for use in dry conditions and over the temperature range -20°C to +70°C, unless otherwise indicated. item must be consulted where products are to be used for applications outside these limits.

Conformity with Directive 2011/65/EU ("RoHS")

item has made a voluntary undertaking to refrain from using hazardous substances as defined in Directive 2011/65/EU in the products it sells, irrespective of their subsequent purpose which, in the majority of cases, does not fall under this Directive.

Concept, design and realisation

item Industrietechnik GmbH

Photographs

item Industrietechnik GmbH

Technical modifications and errors reserved.

All rights reserved. Use of texts and illustrations or reprints of any kind only permitted with our prior written consent. This applies in particular to reproduction, translation or use in electronic systems.

item and the item claim are a registered trademark of item Industrietechnik GmbH.

© item Industrietechnik GmbH 2016

Your distribution and service partner

item

item Industrietechnik GmbH
Friedenstrasse 107-109
42699 Solingen
Germany

Phone +49 212 6580 0
Fax +49 212 6580 310

info@item24.com
item24.com

Your ideas are worth it.®